



FOX Racing Shox

Setup Manual

MOTORCYCLE

Introduction

Thank you for choosing FOX Racing Shox for your motorcycle. In doing so, you have chosen the number one shock absorber in the industry! All FOX Racing Shox products are designed, manufactured and assembled by the finest professionals in the industry. You need to be aware of the importance of setting up your new shock correctly to ensure maximum performance. This manual will provide you with step-by-step instructions on how to set up your shock.

Table of Contents

FOX RACING SHOX History	3
General Information.....	3
Warranty	3
Valving Warranty.....	4
Optional Springs	4
Service.....	4
Methods of Payment	4
Replacement Parts.....	4
Methods of Shipping.....	4
Return Policy	4
International Orders	5
Disclaimer	5
Installation and Basic Set-Up Instructions.....	5
Shock Length Adjustment / Ride Height Adjustment (If equipped)	5
Setting SAG / Spring Preload	5
Damping Adjustment (if equipped)	7
Tuning Instructions	7
Spring Preload.....	7
Ride Height / Shock Length Adjustment (if equipped)	7
When to adjust Ride Height vs. Spring Preload	8
Damping.....	9
Summary of Damping Solutions.....	10
Maintenance Checklist.....	11
Other Maintenance Considerations.....	11

FOX RACING SHOX History

Back in the mid-70's Bob Fox, an avid motocross racer, came to the conclusion that the quality and performance of the shock absorbers available for motocross racing were not up to the extreme demands of the sport. As a mechanical engineer, he saw an opportunity to design and develop a new shock that would surpass the performance of current race equipment. With that goal in mind, Bob designed and began manufacturing a revolutionary high-performance, externally adjustable, air-pressurized shock absorber. FOX AirShox were born!

When Bob first designed shocks for motocross competition, he envisioned a product that would be the very **Best** available. Today, that same philosophy continues to drive FOX RACING SHOX.

We continue to push the envelope in racing shock absorber design, technology and performance shocks for Motorcycles, Snowmobiles, Mountain Bikes, Off-Road vehicles, and ATV's. And we continue to develop our products based on our years of unique experience. Experience that has covered a wide variety of the most extreme, most demanding shock absorber applications on the planet.

The countless lessons we've learned from the many forms of racing and the numerous top racers we've worked with...the expertise we've gained in 25 years of experience...the tiny details of shock design and manufacture that we know are so important...the unique shock designs and technology we've developed...

All of this has been brought together to create one single product...

...A FOX RACING SHOCK for YOU!

General Information

FOX Racing Shox	Phone:	831.768.1100
130 Hangar Way	FAX:	831.768.1186
Watsonville, CA 95076	E-Mail:	sales@foxracingshox.com

Business Hours: Monday-Friday 8:00 AM to 5:00 PM (Pacific Time Zone)

Warranty

The factory warranty period for your shock is one year from original date of purchase of the shock. A copy of the original purchase receipt must accompany any shock being considered for warranty service.

This warranty is void when damage to the shock has occurred from the following:

- Abuse
- Damage to the exterior finish caused by improper hose routing.
- Disassembly
- Modifications
- Non-Factory authorized oil changes
- Shipping damages/loss (purchase of full value insurance is recommended).

FOX Racing Shox reserves the right to all final warranty decisions.

Warranty shipping is customer pre-paid one way. FOX Racing Shox will cover return ground shipping only.

Valving Warranty

FOX Racing Shox guarantees satisfaction with your shock's internal valving. If you are dissatisfied with the internal valving of your shock, FOX Racing Shox will modify the valving at no charge within one year of the purchase of the shock.

Optional Springs

FOX Racing Shox wants you to be able to extract the maximum amount of performance from your FOX shock, therefore, we will recommend one of the spring rates available to ensure that the performance of the shock is matched to your rider weight and riding style. If in the future you would like to change the spring rate on your shock we can sell you additional springs through our aftermarket program. We regret that once a shock has been shipped we are unable to exchange springs, so it is important that you consider any special requirements at the time of purchase.

Service

Each and every FOX shock is carefully manufactured in our Watsonville, California facility. To ensure peak performance, repairs and service to the shock must be performed by FOX Racing Shox or by an authorized FOX Service center. Call (831) 768-1100 to find the service center nearest you. We recommend that you have your shock serviced every two years for shocks used in normal conditions.

Follow this procedure to obtain service or repairs for your shock through FOX Racing Shox.

- Contact FOX Racing Shox for return authorization number and shipping address: (831) 768-1100.
- Send shocks to FOX Racing Shox with shipping charges pre-paid by sender.
- Mark the Return Address and Return Authorization Number clearly on the outside of the package.
- Include a description of the problem(s) with the shock, motorcycle information (manufacturer, year and model) and return address with daytime phone number on a note.

Methods of Payment

VISA, MasterCard, Cashiers Check, COD Cash, Wire Transfers (International Orders)

Replacement Parts

Individual parts, different spring rates, and rebuild kits are available on all current shocks.

Methods of Shipping

All FOX shocks are stocked without springs mounted; we require 48 hours to properly assemble the spring and ship your order. We offer UPS services of Ground, 2-Day, 3-Day or Overnight.

Return Policy

FOX Racing Shox will accept returns on new shock absorbers within 30 days of purchase from FOX Racing Shox. All merchandise must be in the original box and cannot have been mounted on a motorcycle. All returns are subject to a 20% restocking fee.

International Orders

All international orders must be paid in full prior to shipment. We suggest wire transfer, VISA or MasterCard for pre-payments. Freight, any applicable duties or taxes must be pre-paid unless prior arrangements have been made. Our most frequent method of shipping is UPS, but we will ship DHL or another approved international shipper.

Disclaimer

A shock absorber is a key safety component of a motorcycle. FOX Racing Shox recommends that a qualified mechanic install your shock absorber.

Motorcycling is an inherently dangerous activity. Always ride within the limits of your skill and your equipment.

If these setup instructions are not followed correctly, an unsafe condition may exist. If you are uncomfortable or uncertain as to how to install your new FOX shock, have it installed by a qualified mechanic.

Installation and Basic Set-Up Instructions

Follow this sequence of steps to properly install and set up your new FOX shock.

- 1) Remove the stock shock absorber from the motorcycle.
- 2) Set the FOX shock length (if equipped with length adjustment). *See section below.*
- 3) Install the FOX shock on the motorcycle. Torque the mounting fasteners to the motorcycle manufacturer's recommendations.
- 4) Set the *static sag* and *rider sag*. *See section below.*
- 5) Set the rebound damping. *See section below.*
- 6) Set the compression damping (if equipped). *See section below.*

Shock Length Adjustment / Ride Height Adjustment (If equipped)

On some FOX shocks, it is possible to adjust the rear ride height of your bike, by increasing or decreasing the length of your shock. It is best to start out with your FOX shock set to the same length as the stock shock absorber. Once you have adjusted your spring preload and damping to your liking, you can experiment with different rear ride height settings. See **Tuning Instructions** for more information on adjusting rear ride height.

Setting SAG / Spring Preload

After fitting your FOX shock you need to set the *static sag* and *rider sag*. You will need a bike stand that will let your suspension “hang” down in an unloaded position. The rear stand should mount onto the foot pegs or the frame somewhere (not the swingarm), so that the rear wheel is off the ground. If your motorcycle is equipped with a centerstand, that will suffice. If you do not have this type of stand, a couple of strong friends should be sufficient.

- 1) Set the bike up on a suitable stand or get your friends to lift up the rear so the shock is fully extended. Take a measurement from the rear axle to a point on the chassis directly above the rear axle (see Figure 1). This is **L1**; write down this measurement.

- 2) Have a friend hold the front end of the bike. Sit on the bike in your normal riding position. It is also a good idea to have your normal riding gear on including your helmet. If you normally carry luggage on your motorcycle, leave it on the motorcycle for this measurement. Push down on the rear of the bike then let it settle. Measure the distance using the same points as above. This is **L2**; write down this measurement.
- 3) **Rider sag** = **L1** – **L2**. On a street bike this should be 25% to 35% of the total wheel travel, or typically 1” – 1.5” (25-35 mm). On a road race bike this should be ¾” - 1” (20-25mm). (Your motorcycle owner’s manual will tell you the total wheel travel.)
- 4) To set *rider sag* to the correct amount, use the “C” wrench provided and adjust the preload adjuster nuts on top of the spring. Tighten the nut onto the spring to decrease rider sag; loosen the nut to increase rider sag. Repeat steps 2 through 4 until the *rider sag* is in the desired range.
- 5) Push down on the rear of your motorcycle a couple of times and let it settle with no rider on board. Measure using the same points as before. We will call this **L3**; write down this measurement.
- 6) **Static sag** = **L1** – **L3**. The *static sag* should be between 0.25 - 0.5 inches (7-13 mm).



Figure 1: Measuring from the rear axle to a point on the chassis directly above the rear axle

The following chart will enable you to determine if your spring rate is correct. The measurements given are a guide only; there are no absolute settings that you must stick to.

<u>Rider Sag</u>	<u>Static Sag</u>	<u>Spring Rate May Be:</u>
Appropriate Range	Too Little	Too Soft
Appropriate Range	Too Much	Too Hard

Damping Adjustment (if equipped)

Your FOX shock has up to two External Damping Adjustments – rebound damping and compression damping. Rebound damping controls how quickly the shock extends after hitting a bump – more rebound damping means slower extension.

Compression damping controls how quickly the shock compresses in response to a bump. More compression damping means the shock is more difficult to compress.

The blue knob at the lower end of the shock absorber is the rebound adjuster and has approximately 25 positions (see Figure 2). The position of maximum rebound damping is when the knob is turned all the way up towards the main body of the shock until it stops. Do not attempt to force the knob after it stops turning. To check the rebound damping setting, always count the number of clicks as you turn the knob to maximum damping. For example, setting rebound damping “8 clicks out” means turning the rebound damping knob all the way towards the shock body until it stops, then turning it 8 clicks back.

Default rebound damping setting: 10 clicks out

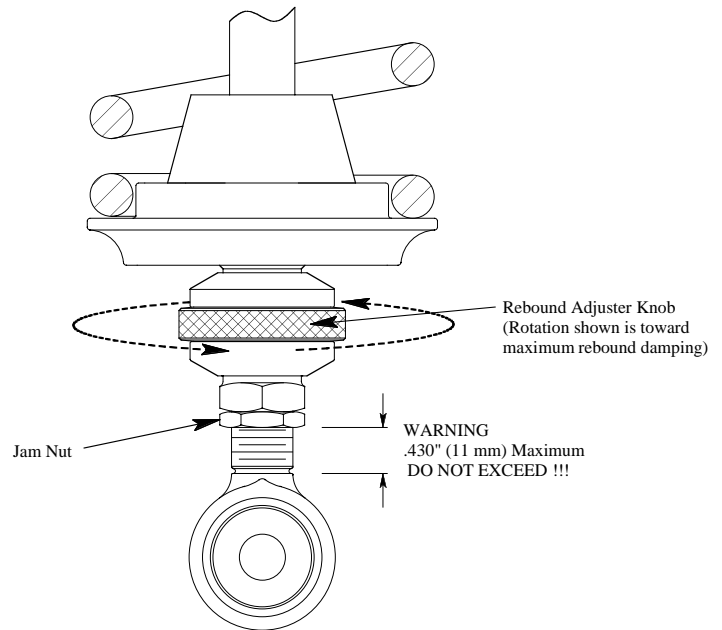

Figure 2: Rebound adjuster and ride height adjuster

The red knob on the reservoir is the compression damping knob and has 8 settings – with 1 being soft and 8 being hard. The numbers line up with a notch on the reservoir.

Default compression damping setting: #3

Tuning Instructions

Now that you have the spring preload and shock length set correctly, it is time to tune the shock to your liking. It is vital that the spring preload be set correctly before any damping changes are made – otherwise you will be starting from a faulty baseline and will have difficulty getting the shock to work properly.

Spring Preload

You might want to experiment with different sag settings to suit your own personal riding style. The settings that you like will also change from bike to bike, and from track to track if you race. Also, different tires make a difference in the settings that you prefer.

Try keeping a note book and experimenting with different set-ups; you will see differences in how your bike steers: more *rider sag* will make it steer “slower”, less *rider sag* will make it steer “quicker”.

Ride Height / Shock Length Adjustment (if equipped)

The overall length of some FOX shocks can be adjusted. This adjustment changes the ride height and can provide a useful tuning tool.

The main reasons to adjust ride height are to change the steering geometry of the motorcycle or to change the ground clearance of the motorcycle. Raising the rear ride height steepens the steering head angle; lowering the rear ride height slackens the steering head angle.

If the cornering clearance on your motorcycle is too low, increasing the rear ride height can reduce the problem. On the other hand, you can lower the seat height by reducing the rear ride height.

NOTE: Most motorcycles were not designed with length-adjustable shocks in mind. Be careful when changing the shock length. Make sure that moving parts like the wheel, swingarm, and fender do not contact the motorcycle chassis at the limits of travel.

The handling of the motorcycle could be adversely affected by changing the rear ride height. Also, decreasing rear ride height will reduce the cornering clearance of the motorcycle.

It is very important that you do not wind out the threaded adjuster more than is shown in Figure 2; do not exceed 0.430 (11 mm) as there will not be enough threads left in the shock absorber and the results could be disastrous.

The shock length may be adjusted while the shock is mounted to the motorcycle. To adjust, place the bike on a stand so the wheel is in the air and the suspension is unloaded. Loosen the jam nut and turn the extension. The eyelet or clevis at the lower end of the shock will remain stationary and the shaft will rotate inside the shock. Be sure to take note of the above warnings.

Here are a few examples of how changing the rear ride height can affect your motorcycle performance:

<u>Symptom</u>	<u>Problem</u>
Motorcycle is unstable at high speeds	Rear Ride Height too high
Poor grip from rear tire	Rear Ride Height too high
Unstable under heavy braking	Rear Ride Height too high
Motorcycle understeers on exit corners	Rear Ride Height too low
Difficult to change direction	Rear Ride Height too low
Poor grip on front tire on exit corners	Rear Ride Height too low

When to adjust Ride Height vs. Spring Preload

You may ask, “How is adjusting shock length different from adjusting spring preload? Don’t they both affect ride height?” The answer – yes, they both affect ride height, but changing spring preload has other side effects.

In a nutshell, spring preload only sets the amount of compression and extension travel available.

When you increase spring preload, you also increase the rear ride height, but at the cost of reduced rider sag. Reducing rider sag will make your shock more likely to top out.

Similarly, reducing spring preload decreases rear ride height, but at the cost of increased rider sag. Increasing rider sag will make your shock more likely to bottom out.

Changing ride height gives you independent control over ride height and travel. For example, suppose you needed to increase the rear ride height to improve cornering clearance. On a stock shock absorber, you would have no choice but to increase spring preload, making the shock top out more often and decreasing ride quality. Changing the shock length could allow you to increase cornering clearance while still maintaining proper travel.

Damping

Perfect damping control is as important as fine tuning your engine. Whether it comes to cutting precious seconds off of your lap times or just obtaining a comfortable ride on a Sunday afternoon, FOX shocks were especially designed to help achieve riding harmony.

The range of damping adjustment on a FOX shock is basically divided into two ranges: Internal and External.

Internal adjustments can only be made by disassembling the shock absorber. This process is called “re-valving”, because the internal valving of the shock is modified. The range of Internal Adjustment is virtually unlimited. We at FOX Racing Shox have spent countless hours of Dyno, track and street testing to give you a shock that just needs to be fine tuned to suit your personal riding style using the external adjustments.

External adjustments can be made at any time and any place. Go out and ride! Focus on what the rear of the bike is doing and not on going 110%. Sometimes you can feel it’s not quite right, for example, but it may be hard to tell if the problem is too little rebound damping or too much compression damping. Sometimes the different “feel” is subtle and you have to really concentrate to tell the difference. An experienced friend watching you ride may be able to help. Try to develop a good “feel” for what is going on. Once you get it right you will be glad you spent the time doing it.

Here is a list of the most common symptoms. It is a good idea to make one adjustment at a time and to keep notes.

Summary of Damping Solutions

Adjustment	Best For Testing	Too much damping when...	Too little damping when...	"Perfect" when...
Low Speed Rebound Damping (Blue knob)	<ul style="list-style-type: none"> • small bumps • sweeper turns • rippled surfaces 	<p>Excess damping keeps the wheel from extending fast enough to follow the low spots between the small bumps.</p> <ul style="list-style-type: none"> • wheel tends to hop on turns with small bumps – especially washboard pavement • rear wheel skips too much when braking on rippled pavement – does not develop good braking power • poor rear wheel traction when accelerating over series of small bumps or rippled pavement <p>In general, suspension action seems well controlled in these situations, but it just doesn't seem to develop good traction.</p>	<p>Similar symptoms to too much low speed rebound, except that the wheel is bouncing too much.</p> <ul style="list-style-type: none"> • Too much kicking up when braking hard going into a tight corner • Bike wallows when exiting corners or in long, rolling dips in sweepers. 	<ul style="list-style-type: none"> • Heavy enough to prevent wallowing or oscillation • Light enough to allow wheel to extend fast enough to maintain good contact with ground. • Bike tracks well on sweepers, brakes well on washboard. • Bike does not wallow when exiting corners, but wheel maintains good contact with ground. • Bike feels stable in corners.
High Speed Rebound Damping (requires valving change)	<ul style="list-style-type: none"> • Series of medium or large rolling-type bumps on high-speed sections • fast sections with deep rolling bumps 	<p>Shock is "packing down": Too much damping keeps the wheel from extending enough before you hit the next bump.</p> <ul style="list-style-type: none"> • Suspension gets harsh over medium or large rolling-type bumps at high speed. The first few bumps in the series don't feel bad, but after that the suspension gets harsh and starts jumping around. 	<ul style="list-style-type: none"> • Wheel kicks up when hitting large rolling-type bumps at high speeds. 	<ul style="list-style-type: none"> • Heavy enough to prevent rear end kicking up or wallowing • Light enough to prevent "packing down" on series of bumps
Low Speed Compression Damping (red knob)	<ul style="list-style-type: none"> • small and medium rolling bumps • rippled pavement 	<ul style="list-style-type: none"> • Shock seems to stay almost rigid, instead of absorbing bumps. • Suspension is harsh over small bumps • Wheel skips when braking hard on rippled surfaces. 	<ul style="list-style-type: none"> • Shock bottoms out on medium-sized bumps. • Rear end squats under acceleration. 	<ul style="list-style-type: none"> • Heavy enough to prevent bottoming out on medium bumps • Light enough to allow shock to stroke smoothly on small bumps • Light enough to avoid skipping when braking on rippled surfaces
High Speed Compression Damping (requires valving change)	<ul style="list-style-type: none"> • Large bumps and sharp-edged bumps • pavement changes 	<ul style="list-style-type: none"> • Suspension is harsh over pavement changes • Shock stays too rigid and doesn't use enough travel to absorb bumps. • Shock rarely or never seems to bottom out even on the biggest bumps. 	<ul style="list-style-type: none"> • Shock takes medium bumps smoothly, but bottoms out too easily on larger bumps • Shock bottoms out too easily on medium to big bumps 	<ul style="list-style-type: none"> • Heavy enough to prevent excess bottoming out • Light enough so shock strokes deeply to absorb these bumps without harshness or rigidity

Maintenance Checklist

Periodically inspect your FOX shock:

- Inspect the chrome shaft surface for damage or wear.
- Inspect the shaft seals for damage or wear. Oil should not normally be visible on the shock absorber shaft.
- Inspect the hose and hose fittings for damage or leakage. Make sure that the hose is not abrading any part of the motorcycle.

Other Maintenance Considerations

- If riding in extreme conditions, service shock more frequently.
- Wash your shock with soap and water.
- Keep away from high pressure washers.